

# Piccolo™ Motor Control Developer's Kits

Power factor correction and sensorless field oriented motor control with one low cost MCU



The new Piccolo F28035 based Motor Control Developer's kits from Texas Instruments leverage the real-time control capabilities of Piccolo, along with TI's industry leading analog, to bring field oriented motor control and power factor correction into cost sensitive applications. Both of these new kits include everything needed to start development: a motor control baseboard, with onboard, isolated USB JTAG emulation, F28035 controlCARD, permanent magnet motors, and a desktop DC power supply.

The software included with these new kits controls up to two permanent magnet motors using sensorless field oriented

control techniques, and is tuned for the motors included with the kit. The software also digitally controls the two phase interleaved power factor correction (PFC) stage.

The PFC plus dual axis baseboard is based around TI's high performance analog technology. Central to the kit are the DRV8402 motor drivers, a single chip dual full bridge motor driver. These 36-pin chips can output 250 watts each at up to 96% efficiency. The baseboard limits each driver to 40W each, due to board size considerations.

These two new motor kits are part of the new C2000™ controlCARD platform.

## Key features

- Power factor correction plus dual or single axis motor control
- Sensorless field oriented control
- Single Piccolo controls PFC and motor control stages
- Piccolo F28035 controlCARD based EVM
- Isolated onboard USB JTAG emulation
- High performance TI analog used in PFC and motor driver stages

Based on a simple daughter card and a common pin-out, the controlCARD allows multiple C2000 MCUs to be evaluated on the same baseboard. TI offers pin compatible controlCARDS for both the Piccolo and Delfino™ MCU families.

The Piccolo F28035 controlCARD included with both motor control kits features the latest Piccolo microcontroller. Running at up to 60 MHz, the F28035 features dual internal oscillators, up to 128 KB of flash, a 12-bit 4.6 MSPS ADC, high resolution ePWM outputs, and the new control law accelerator (CLA). The CLA is an independent, floating-point coprocessor designed to run control algorithms without any CPU involvement. For more information please visit

[www.ti.com/C2000tools](http://www.ti.com/C2000tools).



Kit	Part number	ControlCARD	Motor control baseboard	Motors	Desktop power supply	Price
Motor Control and PFC Developer's Kit	TMDS1MT RPFCKIT	Piccolo F28035	PFC plus dual motor driver EVM w/ isolated USB JTAG emulation	1 permanent magnet motor	24V DC 60W universal power supply	\$369
Dual Motor Control and PFC Developer's Kit	TMDS2MT RPFCKIT	Piccolo F28035	PFC plus dual motor driver EVM w/ isolated USB JTAG emulation	2 permanent magnet motors	24V DC 60W universal power supply	\$399

Software, documentation, and hardware schematics, Gerber files, etc. can be downloaded for free at [www.ti.com/c2000tools](http://www.ti.com/c2000tools).

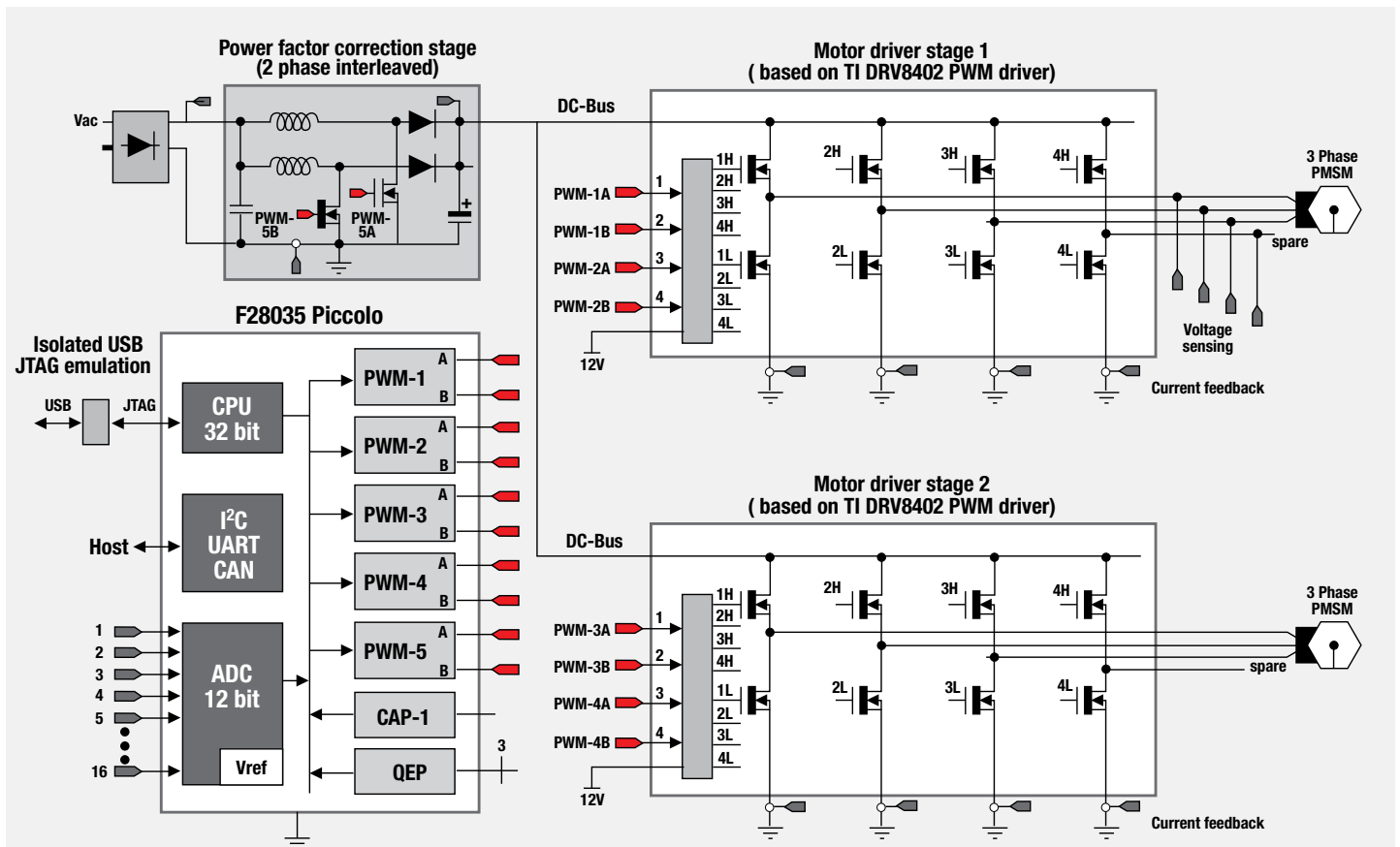

Piccolo F28035 block diagram

**Important Notice:** The products and services of Texas Instruments Incorporated and its subsidiaries described herein are sold subject to TI's standard terms and conditions of sale. Customers are advised to obtain the most current and complete information about TI products and services before placing orders. TI assumes no liability for applications assistance, customer's applications or product designs, software performance, or infringement of patents. The publication of information regarding any other company's products or services does not constitute TI's approval, warranty or endorsement thereof.

The platform bar, C2000, Piccolo and Delfino are trademarks of Texas Instruments.  
All other trademarks are the property of their respective owners.

B010208